

INSTRUCTION MANUAL

P750 Sliding Gate Motor
P550 Sliding Gate Motor

Version -V2.X



IMPORTANT SAFETY WARNING



ATTENTION To prevent electrical shock, disconnect from power source before installing or service



ATTENTION Electricity and power motors associated accessories could be fatal or at least cause seriously injury. ***All main voltage wiring must be installed by a licensed electrician.***



ATTENTION Additional safety device **MUST** be fitted such as Photo Electric Beam, Loop Detectors.



ATTENTION Before do the manual release, the mains power switch must be off even there is no power.



ATTENTION Before power on, the manual release **MUST** engaged



ATTENTION Gate opened stopper and closed gate stopper **MUST** be installed.



P550 Sliding Gate Motor

GENERAL LAYOUT

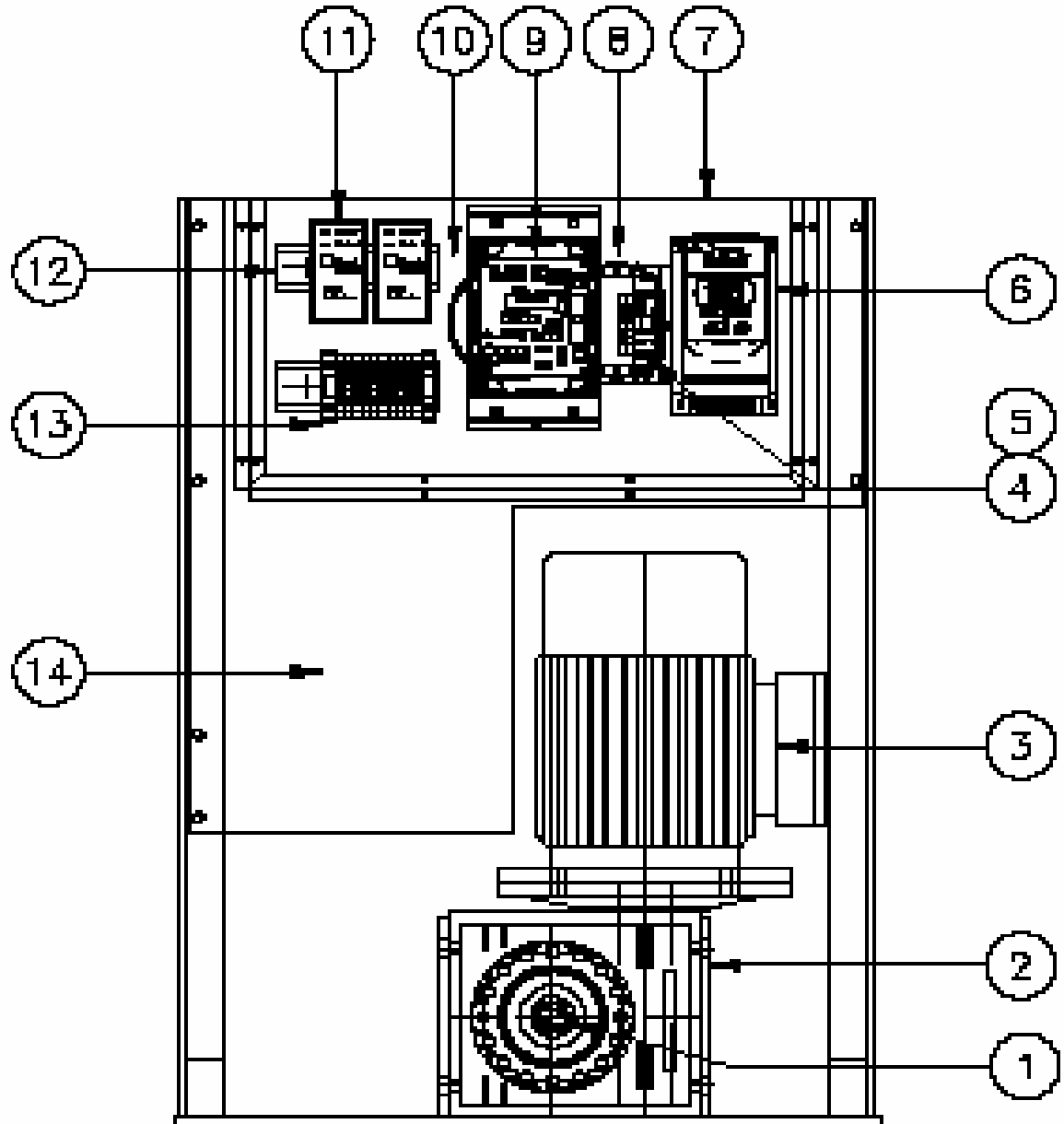

Fig -1

- | | |
|------------------------------|------------------------------|
| 1) Manual Release bolts | 2) Gear box |
| 3) Motor | 4) Circuit breaker |
| 5) Terminals | 6) Inverter |
| 7) Perspex | 8) EMC filter |
| 8) Main control board | 10) Transformer |
| 11) Loop detector (option) | 12) Din rail |
| 13) Access control terminals | 14) Room for other accessory |

CONTROL INPUT AND BUTTON

1. General Descriptions

The P550 and P750 sliding gate motors was designed for heavy duty industry track gate or cantilever gate. Heavy duty three phase industry motor driven by VSD (variable speed drive), gate can run at different speeds. Built in encoder and intelligent controller combination can make the gate running more smoothly. The controller can receive the signals from swipe card, loop detectors, remote control, photo-electric beams and any kind of access control system. Galvanised metal sheet and powder coated high quality cabinet(1.5mm thickness) has remove door (P750) and plenty of room for the access control accessories including din rail mounting. 50VA transformer (12V/24v/2A) can directly drive magnetic lock, warning lights etc.

2. Technical Specifications

| | |
|--------------------------|--|
| Power supply | 230/240V AC at 10A |
| Output voltage | 230V AC three phase (via) inverter, Max. 0.75KW |
| Motor rate | Three phase two poles 0.55KW (P550) or 0.75KW (P750) |
| Gate type | Track or cantilever |
| Drive speed | Up to 700mm/sec (with big opinion) |
| Max. gate length | No limitation |
| Fully programmable | Auto close time, PE trig close time etc. |
| Accessories power supply | 12V@2A or 24@2A, Max. 50VA, protected by 1A fuse |

3. Control Board layout

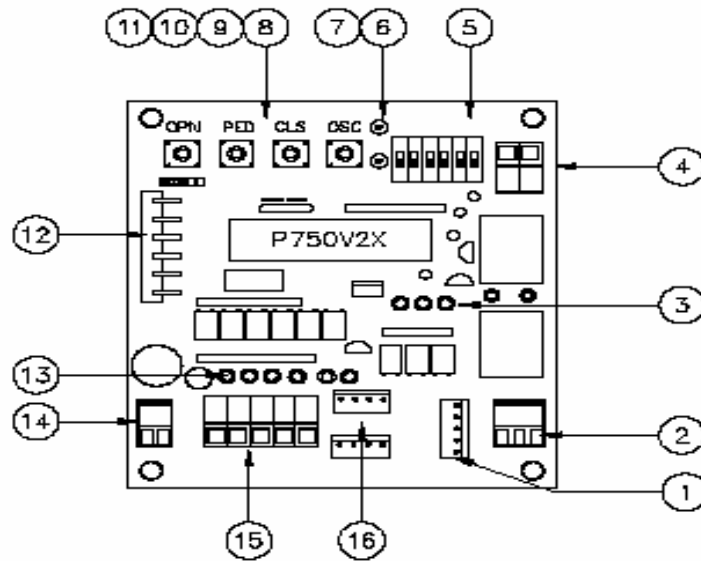

Fig-2

- | | |
|--------------------------------|----------------------------------|
| 1) Plug to the inverter | 2) Lock relay output |
| 3) Drive signal LED | 4) Gate closed relay output |
| 5) DIP switch | 6) Gate status display LED-Green |
| 7) Gate status display LED-Red | 8) OSC open/stop/close button |
| 9) CLS close button | 10) PED pedestrian button |
| 11) OPN open button | 12) 6 pins remote plug |
| 13) Control signal display LED | 14) Input interface power 12V AC |
| 15) Control signal plug | 16) Encoder plug |

CONTROL INPUT AND BUTTON

Open (OPN) input & OPN push button

The OPN inputs are Push Button OPN and Terminal OPN input. Push OPN button or Activating (connect OPN terminal to the COM (+12V)) the OPN input will start the gate to open. When gate opened, if OPN is still activating, the gate will stay open.

Pedestrian Access (PED) input and Pedestrian (PED) push button

The pedestrian input partly opens gate.

CLS push button

The CLS push button on control board is to close gate.

OSC (open/stop/close) input and OSC push button

OSC input and OSC push button is for manual operation. Push to open the gate, push again stop gate, another push close the gate. When gate stopped by OSC input, auto close mode does not apply.

Photoelectric safety beam (PE) input

If the P.E input activated while gate is closing, the gate will stop or reopen depending on the DIP setting. If the gate in the opened position and P.E beam activated, the gate will stay in opened.

Encoder inputs

Encoder in mounted on the motor shaft. There is not service is required. 4 pins socket from encoder directly plug in on the control board. Two plugs on the control board are for right hand or left hand gate.

Drive signals (between control board and inverter)

Plug 1 link inverter and control board. This is five pins plug. Two pins for 12VDC supply from inverter to control board and other three pins is from control board to inverter, open, close and running frequency signals.

Lock output signal

Lock output relay has COM, N/C, N/O outputs. The output can be pulse or presence set by DIP3.

Gate close (status) output signal

When gate in closed position the relay contact is on, this used to send closing signals to alarm system. As long as the gate is not closed, the relay contact will be off and tell the alarm system, the gate is open.

4. DIP SWICTH FUNCTION

SET/RUN (DIP1)

Dip1 ON selects setting mode.

ON=SET,

OFF=RUN

Slave/Master (DIP2)

This is for two motors (reserved for late use)

ON=SLAVE

OFF= MASTER

LOCK Output (DIP3)

DIP3 ON selects lock output is pulse at every start cycle. DIP3 OFF selects lock output is presence. The lock relay will be on if the gate is in opening and closing cycle. All other situations will be off.

ON= PLUSE

OFF= PRESENCE

Security close (DIP4)

DIP4 ON selects security close mode. In this mode, while the gate is opening, if the PE beams triggered and clear, the gate stops and begins to close; even it is not fully open. While the gate is closing, if the PE triggered, the gate will stop (not reopen) until the PE beams is clear, then gate continues to close. DIP4 OFF no this function. DIP4 is prior to DIP5

ON=SEC CLS

OFF=NO SEC CLS

PE trig close (DIP5)

DIP5 ON selects PE beam trig auto close mode. In this mode, if P.E beams triggered and clear the gate will auto close after gate opened. If the P.E beams trig again, the gate will reopen as long as the P.E input active,

ON=PE CLS

OFF=NO PE CLSDIP5 ON selects PE

CONTROL BOARD SETTING

until gate is fully opened. If the PE is clear, the gate will open another 2 seconds, then gate will close again after PE close delay time. DIP5 OFF no this function. DIP5 is prior to DIP6.

Auto CLS (DIP6) ON=AUTO CLS OFF=NO AUTO CLS
DIP6 ON selects Auto close mode. In this mode, the gate will auto close after standard auto closed time. If DIP6 OFF, no this function.

5. Timer Settings

Push Buttons functions

| Button | Dip1 on---STD Setting | SPE Setting | Dip1 off---Running |
|--------|-----------------------|---------------------|--------------------|
| OPN | Open Length Set | Sync delay time | Full open |
| PED | Auto close time set | Motor stop time set | Pedestrian open |
| CLS | Manual close gate | PE close time set | Close |
| OSC | Lock pulse time set | Reserved | OSC |

5.1 STD(standard) time setting mode

To get into standard setting mode, just set DIP1 to on. Following settings can be set in standard setting model

Gate length set up -- Limit switch set up

- a) Connect 240V AC (if not done) and make sure power is off.
- b) Releases clutch and push gate to middle position, and then engage the clutch.
- c) Make sure no signals connect to OPN, PED, OSC and PEB terminals. Set DIP6 on.
- d) Turn power on, gate should start close at low speed. If not, turn power off, change motor direction by swapping any two of three phases (from motor side)
- e) Power on again. Gate should start to close. Look at RED LED should be flash and GREEN LED is off. If not, turn power off, change encode plug to other connector.
- f) Power on again, gate start close, RED LED is flash and GREEN LED is off. When gate hit the closed stopper, gate will stop. For P550 the gate will open a little bit, do not move the gate, just go to next step.
- g) Set DIP1 on. Push and hold OPN button, gate will start open at low speed. When gate reach opened position, (about 50mm away opened stopper). Just simply release the OPN button. Controller will save the current position as fully opened position. While hold OPN button, push and release PED button will save current gate position as PED opened position.
- h) Set DIP1 off and push CLS button, gate will start to close. When gate fully closed, gate will be ready to operate. Then try to open and close. If not satisfied with the position, just repeat step (g) to (h).

Auto close time set

Push and hold on PED for the auto close time setting. Now the red and green LED flash fast alternatively, When reached the required time simply release PED button. Set DIP1 OFF. The gate controller will back to working mode.

Lock pulse time set

Push and hold on OSC for the lock pulse time setting. Now the red and green LED flash fast alternatively, and when gate reached the required time, simply release OSC button. Set DIP1 OFF. The gate controller will back to working mode.

5.2 SPE(special) time setting mode

To get into special setting mode, turn power off, set DIP1 on. Push and hold CLS button then turn power on, LED will be on for short time, after LED off simply release CLS button. Gate controller is getting into special time setting mode.

CONTROL BOARD SETTING

Sync delay time (Motor2 delay time, reserved late use)

After controller get into special time setting mode, Push and hold on OPN for the sync delay time setting. Now the red and green LED flash fast alternatively, when reached required time, simply release OPN button. If no other time need set, simply set DIP1 off, the gate controller will back to working mode.

Motor Stop time

Push and hold on PED for the motor stop time setting. Now the red and green LED flash fast alternatively and when gate reached required time, simply release PED button.

PE trig close time

Push and hold on CLS for the PE trig close time setting. Now the red and green LED flash fast alternatively and when gate reached required time, simply release CLS button.

Reserved

Push and hold OSC reserved late use.

Factory default setting

| Timer | F/Setting | Step | Setting Method | Range |
|--------------------|-----------|---------|---------------------|---------------|
| Full Open Length | 10M | 0.7mm | STD& OPN Button | No limitation |
| PED Open Length | 5M | 0.7mm | STD& OPN+PED Button | No limitation |
| Auto Close Time | 30sec. | 0.1sec. | STD& PED Button | 0-6550sec. |
| Lock Pulse Time | 0.8sec. | 0.1sec. | STD& OSC Button | 0-25sec. |
| Motor Stop Time | 1.0sec. | 0.1sec. | SPE& OPN Button | 0-25sec. |
| Sync Delay Time | 0.5sec. | 0.1sec. | SPE& PED Button | 0-25sec. |
| PE Auto close Time | 2sec | 0.1sec | SPE& CLS Button | 0-25sec |
| Reserved | 0 | 0 | SPE& OSC Button | 0 |

To restore factory setting, turn power off and set DIP1 on, push and hold CLS button then power on. While hold CLS button, set DIP1 off, release the CLS button. Now controller restored factory setting from memory.

Attention: First time power up, the motor will run at low speed in close direction (if DIP6 is on) and hit receiving post. Next open command gate will open at low speed until to fully opened. The controller will calculate the gate length and compare it with original gate length. If it is right, the gate will back to normal operation, otherwise, gate will run at low speed.

6. Inverter settings

When the gate stops, the inverter's display is opening high-speed frequency and flash. This frequency can be changed by up and down arrows on the inverter. The following form is the inverter's standard setting for the automatic gate application. *Not mentioned function keep as factory setting.*

| Function | F | Function Description | Setting | Unit | Note |
|----------------------|-----------|------------------------------|-----------|-----------|------|
| Acceleration time | 1 | Acceleration time | 2.0 | Sec. | |
| Deceleration time | 2 | Deceleration time | 2.0 | Sec. | |
| Freq. Upper limit | 6 | Max. Frequency | 60 | Hz | |
| Freq. Lower limit | 7 | Min. Frequency | 0 | Hz | |
| SP1 Frequency | 8 | Gate Close High Speed | 35 | Hz | |
| Start/Stop/Control | 10 | Terminals | 1 | | |
| Multifunction Input | 20 | Reset Terminal Function | 6 | | |
| SP2 Frequency | 26 | Gate Open Low Speed | 20 | Hz | |
| SP3 Frequency | 27 | Gate Close Low Speed | 15 | Hz | |
| | | | | | |

WIRING DIAGRAM

7. Wiring diagram

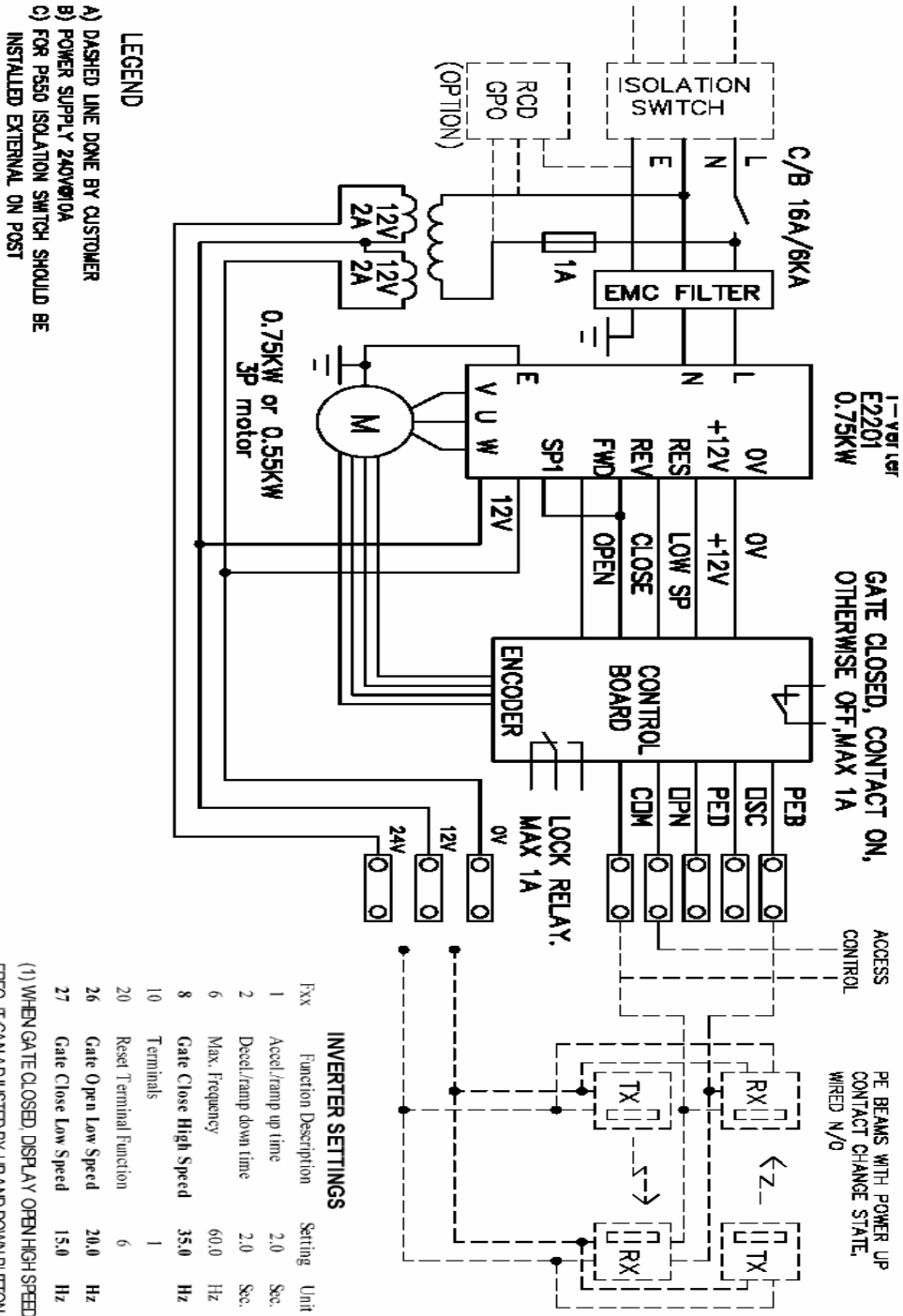

MANUAL RELEASE

8. Manual release

P550 and P750 have different manual release mechanisms please read the instructions carefully.

8.1 P550 manual release

A: What to do during a power failure:

The gate can be manually pushed open and close if there is no power. To do this, you need to release the release bolt.

- (1) Switch off the power switch at the mains supply.
- (2) Open the front flap and insert the spanner (provided) into the hole. The spanner should fit onto the bolt nicely.
- (3) Rotate the spanner **anti-clockwise** several times (6-8 turns) until light resistance is felt. **Do not force.**
- (4) The gate can now be manually opened and closed.

B: What to do if power is reconnected:

At this stage, the gate should be able to be pushed open and close manually (using hands). If not, read and carry out instructions in 'What to do during a power failure' **first**, before carrying out these instructions.

- (1) Make sure the switch at the power point is still switched OFF.
- (2) Open the front flap and insert the spanner (provided) into the hole. The spanner should fit onto the bolt nicely.
- (3) Rotate the spanner **clockwise** until light resistance is felt. **Do not force.**
- (4) (a) Manually push or pull the gate until a clicking noise is heard or if it cannot be pushed any further.
 (b) If no click is heard **AND** the gate is still able to be pushed fully open, turn the spanner **clockwise** a little more (half a turn – Do not use force) and try this step 4(a) again.
- (5) If needed, rotate the spanner **clockwise** again until finger-tightness is felt. **Do not force.**
- (6) Turn on the power at the power point. , the gate should start to close if no signal input on PEB (safety) and OPN (open) inputs. When gate hit on receiving post, the controller will recall the all the settings and ready to operate.

MANUAL RELEASE

8.2 P750 manual release

A: What to do during a power failure:

The gate can be manually pushed open and close if there is no power. To do this, you need to release the release bolt.

- (1) Open the front door and turn the switch(circuit breaker) OFF(even though there is no power)
- (2) Fit spanner (provided) onto the manual release bolt nicely.
- (3) Turn the spanner **anti-clockwise** 1 turn. Take the spanner off the manual release bolts. The gate can now be manually opened and closed.
- (4) After the gate was pushed to the required position, fit the spanner onto the manual release bolts, clockwise turn and make the bolts tight, otherwise maybe cause oil leaking.

B: What to do if power is reconnected:

- (1) Make sure the switch (circuit breaker) is still OFF.
- (2) Fit the spanner onto the bolt nicely and clockwise turn the manual release bolts and make sure the bolts is tight
- (3) Turn on the switch on, the gate should start to close if no signal input on PEB (safety) and OPN (open) inputs
- (4) When gate hit on receiving post, the controller will recall the all the settings and ready to operate.

9. Trouble Shooting Guide

9.1 Display information on main control board – see Fig-2

(1) Gate status LED

| Gate Status(Position) \ LEDs | Status LED-Green (6) | Status LED-Red (7) | |
|------------------------------|----------------------|---------------------|--|
| Gate in closed position | Slow Flash | on | |
| Gate is opening | Fast flash | off | |
| Gate in opened position | on | Slow flash | |
| Gate is closing | off | Fast flash | |
| Gate stop in the middle | Alternatively flash | Alternatively flash | |

Gate stop in the middle: which means the gate stop by OSC input and at this position the auto close does not apply. If the gate hit something or mechanical jammed, gate will stop and green and red status LEDs alternatively flash.

(2) Input LEDs

| Inputs LEDs\ Input status | Input Active | Input inactive | |
|------------------------------|--------------|----------------|--|
| Open input –OPN LED | on | off | |
| Pedestrian input – PED LED | on | off | |
| Open/Stop/Close – OSC LED | on | off | |
| Photo Electric Beam- PEB LED | on | off | |
| Encoder input -A | On or off | On or off | |
| Encoder input -B | On or off | On or off | |

(3) Drive Signal LEDs

| Drive Signal LEDs\ Output status | Input Active | Input inactive | Gate Status |
|----------------------------------|--------------|----------------|--------------|
| Gate opening- Green LED | on | off | Gate opening |
| Gate closing – Red LED | on | off | Gate Closing |
| Low speed – Yellow LED | on | off | Low speed |

9.2 Trouble Shooting Guide

| Malfunction | Possible causes | Countermeasure |
|---|---|--|
| Gate not open | 1) No power 2) Already in opened position | 1) Check the power 2) First time power up, for safety reason, the controller treated current position as opened position. |
| Gate not close | 1) Safety input PEB active 2) OPN input active | 1) Check the safety device, N/O contact required. 2) Check access control system |
| Gate run little bit then stop and Status LEDs flash | 1) No encoder input 2) mechanical jammed | 1) Aux. power supply fuse 2) power off and disengage the motor and push and pull the gate manually |
| Gate opened or closed position not right | 1) mechanical release bolts not tight (P750 only) | 1) Power off and tight the bolts(P750 only) and power again. Please follow the manual release procedure. |

CONDITION OF SALE